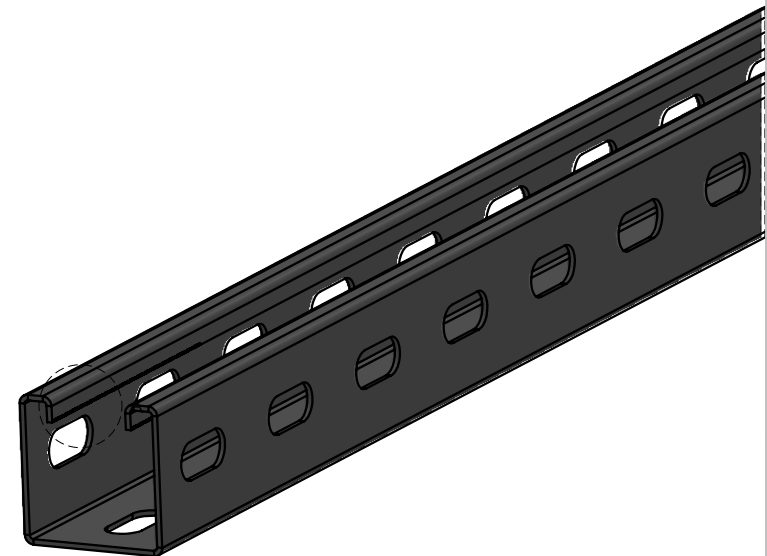
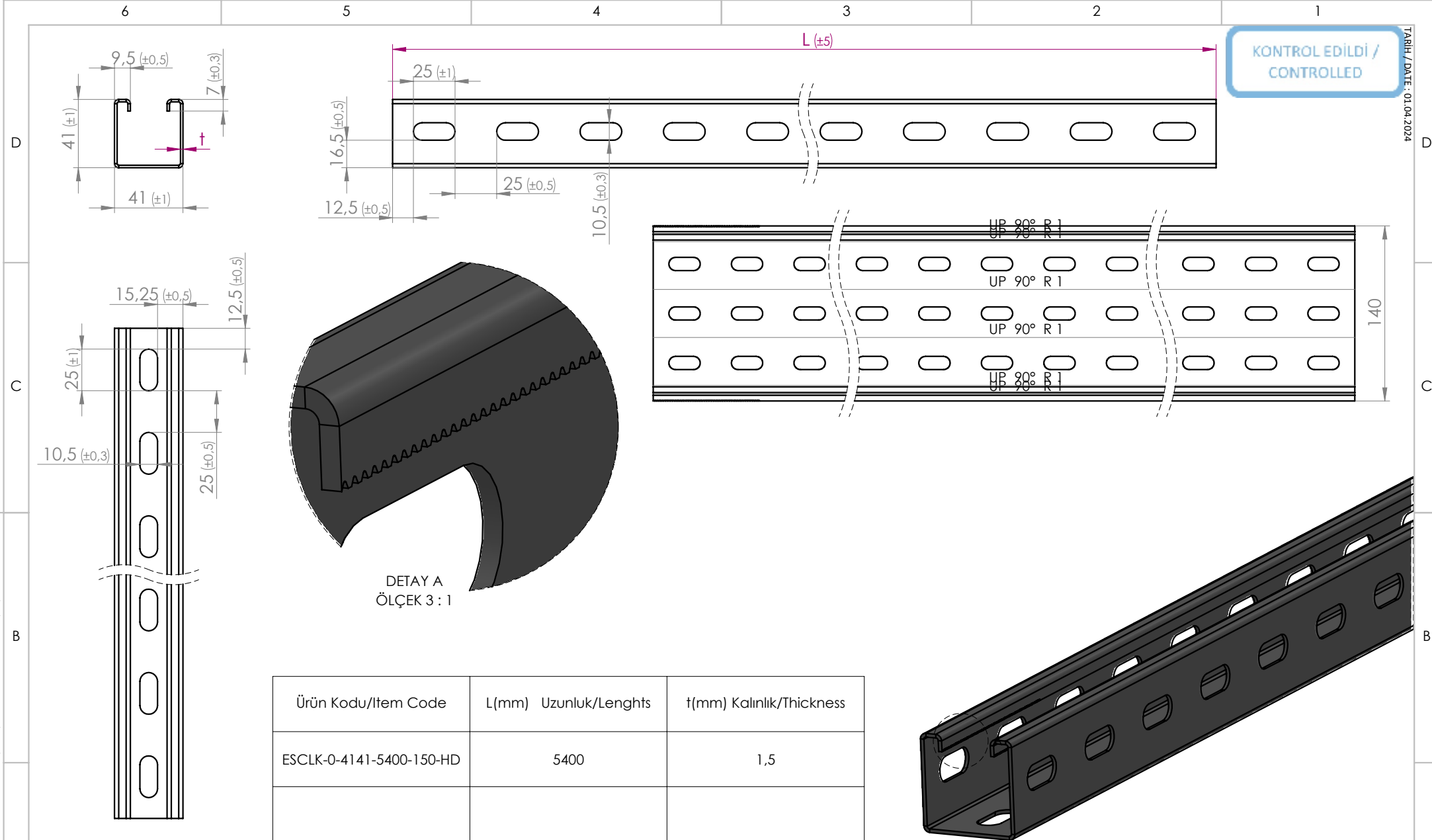

KONTROL EDİLDİ /  
CONTROLLED

KAPLAMA TÜRÜ / Coating Type

HOT DIP GALVANIZED

MALZEME / Material

S 235

KAPLAMA STANDARTI / Coating Standard

TS EN ISO 1461 / TS 822

Verilmeyen Toleranslar için ISO 2768 Orta Seri Toleranslar Kullanılacaktır.  
ISO 2768 Medium Class Tolerances must be used to Undefined Tolerances.

Linear Ölçüler için Genel Toleranslar /

General Tolerances for Linear Dimensions (DIN ISO 2768 T1)

Ölçü Aralığı / Range of Nominal Sizes (mm)	> 0,5 ≤ 3	> 3 ≤ 6	> 6 ≤ 30	> 30 ≤ 120	> 120 ≤ 400	> 400 ≤ 1000	> 1000 ≤ 2000	> 2000 ≤ 4000
Tolerans / Tolerances (mm)	± 0,1	± 0,1	± 0,2	± 0,3	± 0,5	± 0,8	± 1,2	± 2,0

PARÇA NO / PART NO : ESCLK-0-4141

TANIM / Description

C PROFİL (Tırtıklı)

C Profile (Serrated)

ÇİZEN / Drawn by

TOLGA ALGAN

TARİH / Date

01.04.2024

KONTROL / Checked by

KADİR ÇAKIR

01.04.2024

ONAY / Approved by

KADİR ÇAKIR

01.04.2024

İSİM / Name

İMZA / Signature

ÖLÇEK / Scale

1:100

Sayfa / Sheet

1 / 1

A4L

Rev. Modification Date Prepared by Approved by Signature